

REV	DESCRIPTION	DATE

NOTES

MATERIAL TOP & BOTTOM 0.062" STEEL, SIDES, FRONT, REAR & HORIZONTAL SUPPORTS 0.125" ALUMINUM, DIMENSIONS ARE TAKEN WITH THE PAINTED SURFACE

FINISH TOP, BOTTOM & SIDE PANELS, TEXTURED BLACK, FRONT/REAR PANELS ON SMOOTH BLACK, ONE CONTEMPRA GRAY (RAL 7032), ALL POWDER PAINT,

FRONT VIEW

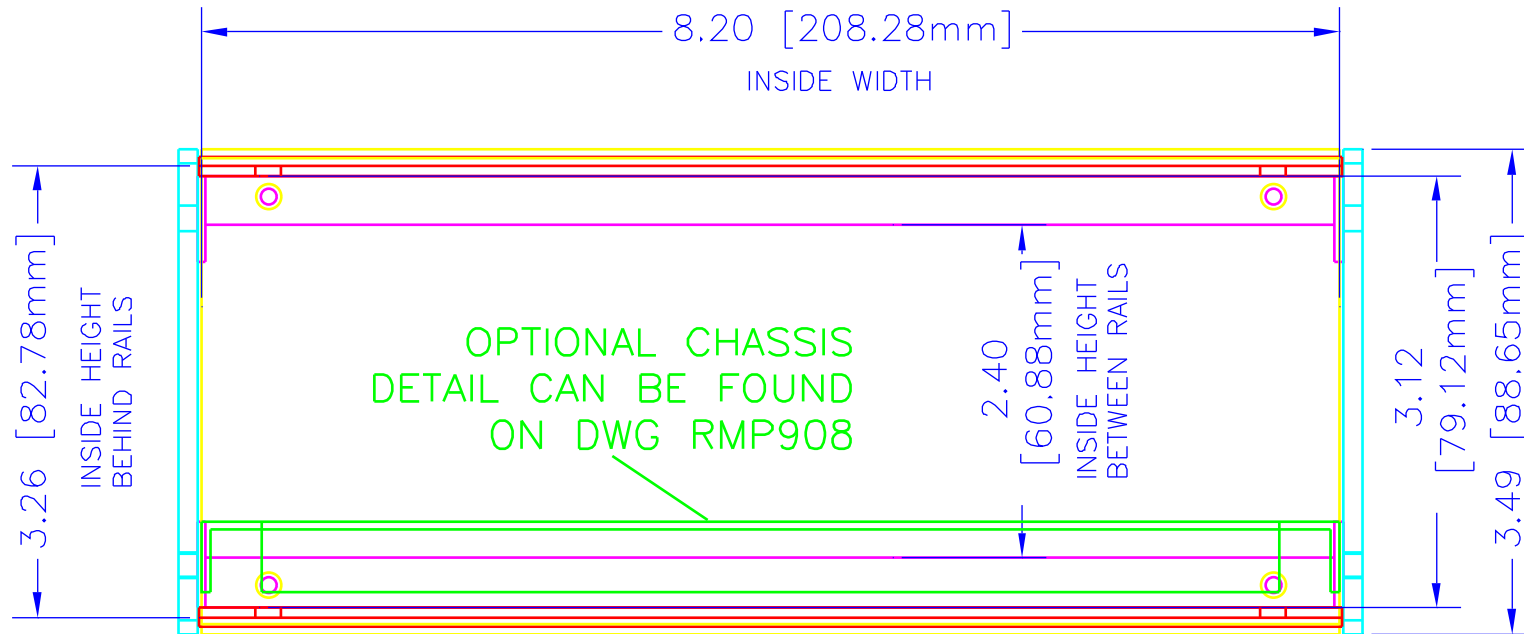

UNLESS OTHERWISE SPECIFIED
DIMENSIONS ARE IN INCHES

X +/- .1
XX +/- .02
XXX +/- .015
CUTS +/- .005
ANGLES +/- 5 DEG.



**HAMMOND
MANUFACTURING**

WEB: WWW.HAMMONDMFG.COM

TITLE HAMMOND RMCV SERIES
RACK ENCLOSURE

DRAWN BY MJM DATE 10/18/01

SCALE PAGE 1 OF 3

PART NUMBER

RMCV9038

SIDE VIEW

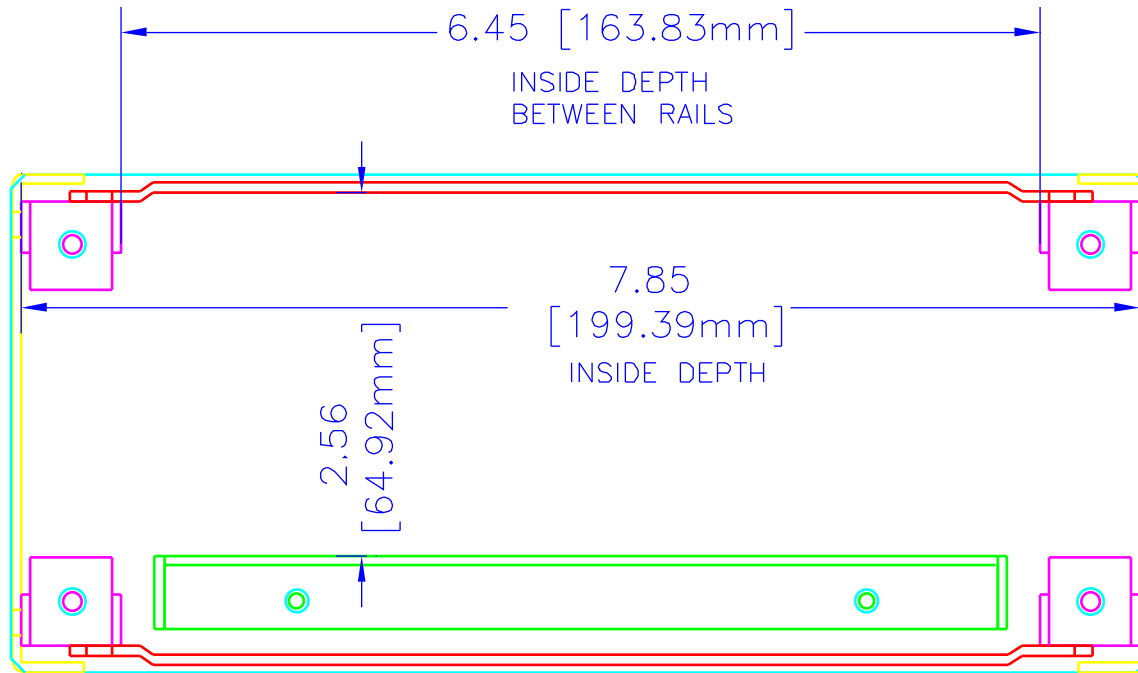

UNLESS OTHERWISE SPECIFIED
DIMENSIONS ARE IN INCHES

X +/- .1
XX +/- .02
XXX +/- .015
CUTS +/- .005
ANGLES +/- 5 DEG.



**HAMMOND
MANUFACTURING**

WEB: WWW.HAMMONDMFG.COM

TITLE HAMMOND RMCV SERIES
RACK ENCLOSURE

DRAWN BY MJM DATE 10/18/01

SCALE PAGE 2 OF 3

PART NUMBER

RMCV9038

HAMMOND MANUFACTURING RESERVES ALL RIGHTS TO THE MATERIAL ON THIS DRAWING. IT IS INTENDED TO BE USED AS A REFERENCE FOR ENGINEERING INFORMATION ONLY. THIS INFORMATION MAY NOT BE USED TO MANUFACTURE PRODUCT WITHOUT WRITTEN PERMISSION FROM HAMMOND MANUFACTURING.

TOP VIEW

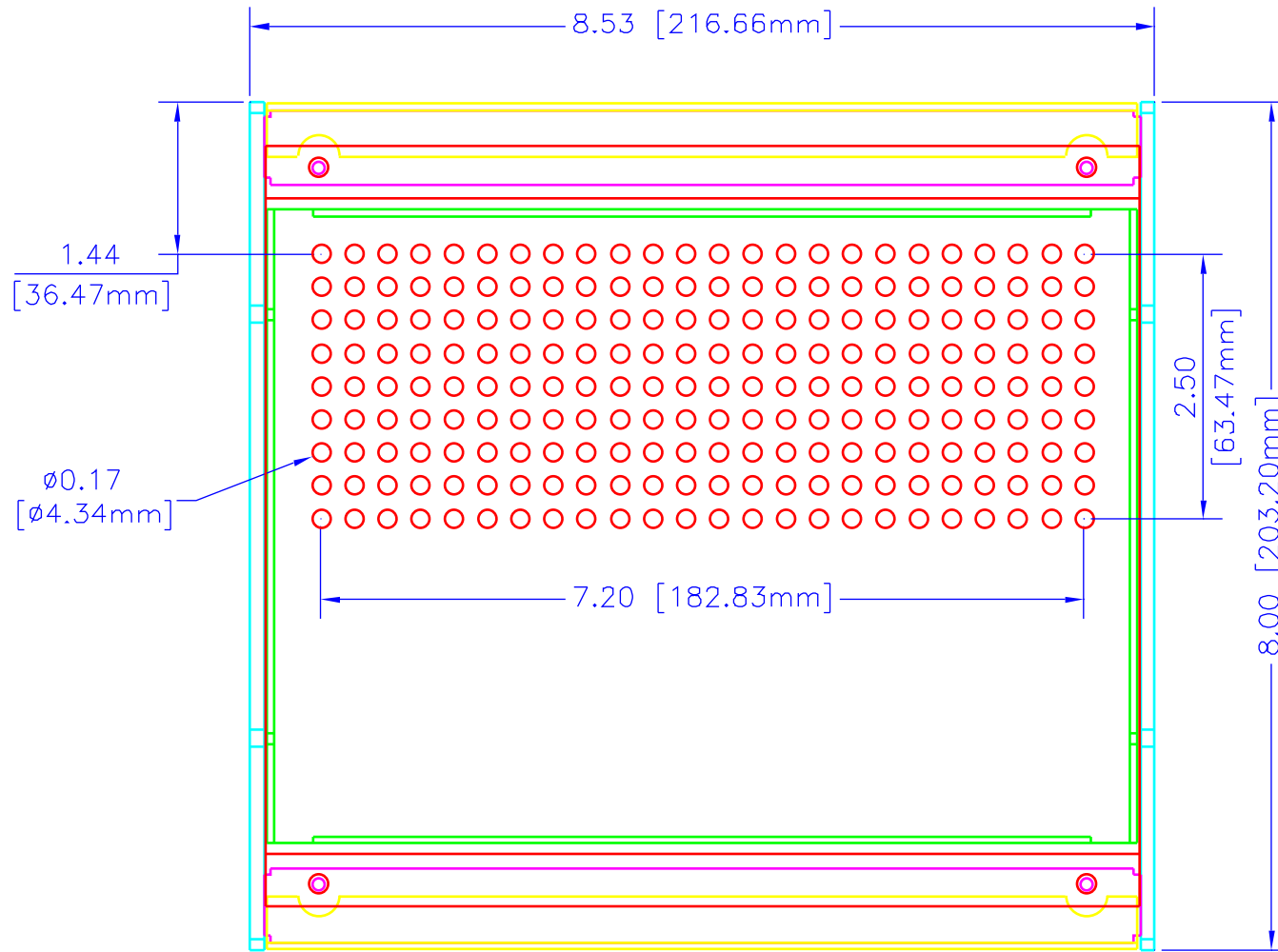

UNLESS OTHERWISE SPECIFIED
DIMENSIONS ARE IN INCHES

X	+/- .1
XX	+/- .02
XXX	+/- .015
CUTS	+/- .005
ANGLES	+/- 5 DEC.

SMITH
HAMMOND RESERVES ALL RIGHTS TO
THE MATERIAL ON THE DRAWING. IT IS
INTENDED TO BE USED AS A REFERENCE FOR
ENGINEERING INFORMATION ONLY. THIS
INFORMATION MAY NOT BE USED TO
MANUFACTURE PRODUCT WITHOUT WRITTEN
PERMISSION FROM HAMMOND MANUFACTURING



**HAMMOND
MANUFACTURING**

WEB: WWW.HAMMONDMFG.COM

TITLE
HAMMOND RMCV SERIES
RACK ENCLOSURE

DRAWN BY MJM DATE 10/18/01

SCALE PAGE 3 OF 3

PART NUMBER

RMCV9038